

Carlo Salvi Headers

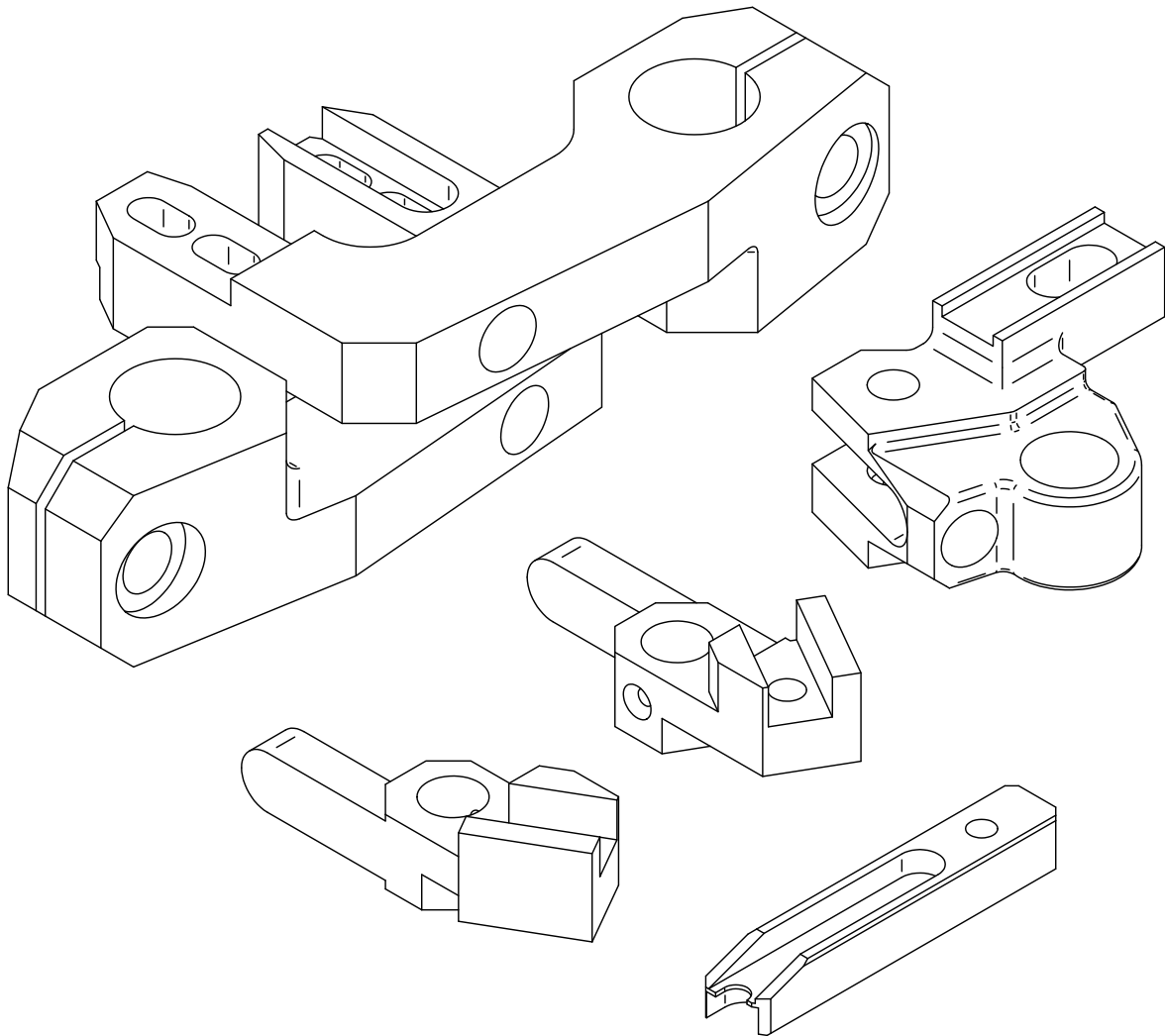

**When quoting or placing an order,
specify the following:**

- **Catalog & Page Number**
- **Machine Size**
- **Key Number**
- **Quantity**
- **Part Number (if available)**

**Please provide sample parts or prints
for items not found in this catalog.**

We at Star Metal Products look forward to serving you, and encourage you to review the following terms and conditions to ensure a mutually successful business transaction.

- Terms are net 30 days from shipment, F.O.B. Ourdock, Westlake, Ohio Freight Collect. All prices subject to change without notice.
- Our minimum billing is \$50.00
- Quotations are valid for 90 days unless otherwise specified.
- Star Metal Products Blanket Order Policy
Duration: Blanket Orders will be held for a maximum time period of six months. Any line item open six months from the date of receipt of customer order will ship automatically. Duration of blanket order may extend up to one year, only if specific release quantities and release dates are supplied with customer order.

Releases: Upon completion of job order, 25% of each line item (with a minimum of 1 piece) will be shipped to customer. The balance of each line item will be held for release by customer within the six month time frame.
- Cancellation will be subject to a charge for any applicable material used and labor employed for work in progress.
- Returns: We regret that positively no tooling may be returned without factory authorization. Returns must be made within 60 days of receiving merchandise. We will not be responsible for shipping charges incurred by customers that deviate from this policy. We reserve the right to only repair tooling accepted under these conditions.

TOP FINGER

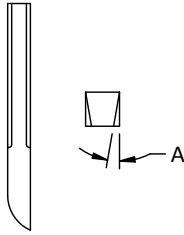

| Machine | Finger (A) | Finger Holder |
|-------------|--------------|---------------|
| 1/8 (330) | 3-1302 (10) | 3-1302TFH |
| 1/8 (330) | 3-1302A (15) | 3-1302ATFH |
| 3/16 (550) | 3-1303 (10) | 3-1303TFH |
| 3/16 (550) | 3-1303A (15) | 3-1303ATFH |
| 1/4 (246) | 3-1301 (10) | 3-1301TFH |
| 1/4 (635) | 3-1304 (10) | 3-1304TFH |
| 11/32 (873) | 3-1305 (10) | 3-1304ATFH |

TOP FINGER HOLDER

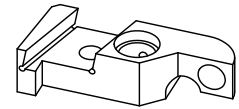

BOTTOM FINGER

LONG MEDIUM SHORT

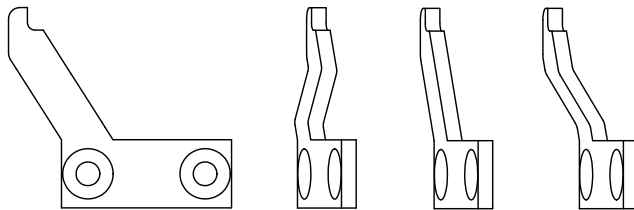

BOTTOM FINGER HOLDER
SPECIFY OLD OR NEW STYLE

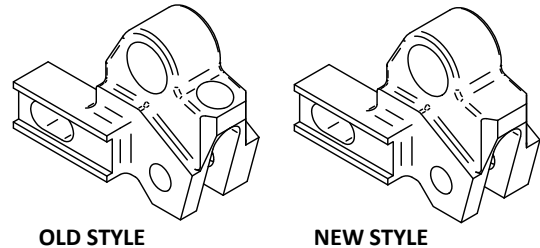

| Machine | Finger Type | Finger | Finger Holder | Finger Block |
|----------------|-------------|---------|---------------|--------------|
| 246TR | LONG | 3-1313 | 3-1318 | 3-1319 |
| 3/16 (476,550) | SHORT | 3-1301S | 3-1311 | 3-1315 |
| 3/16 (476,550) | MEDIUM | 3-1310S | 3-1311 | 3-1315 |
| 3/16 (476,550) | LONG | 3-1300S | 3-1311 | 3-1315 |
| 1/4 (635) | MEDIUM | 3-1306S | 3-1312 | 3-1316 |
| 1/4 (635) | LONG | 3-1307S | 3-1312 | 3-1316 |
| 11/32 (873) | SHORT | 3-1308S | 3-1314 | 3-1317 |
| 11/32 (873) | LONG | 3-1309S | 3-1314 | 3-1317 |

FINGER BLOCK

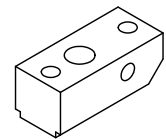

246 TRANSFER ARMS

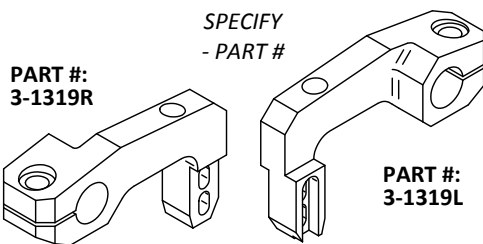

SPECIFY
- PART #

PART #:
3-1319R

PART #:
3-1319L

CUTOFF KNIFE

(3-SV180C = W/ CARBIDE)

| Machine | Part # |
|-----------------------|---------|
| 1/8 PSV-RF/SV | 3-SV125 |
| 5/32 TP2/CL RF/PL | 3-SV150 |
| 3/16 47615V-RF147615V | 3-SV180 |
| 1/4 635/SV-RF/635/SV | 3-SV250 |
| 1/4 INT/CL-RF/ML | 3-SV260 |
| 5/16 RF/873/SV | 3-SV312 |

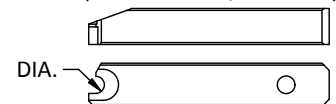

SPECIFY
- PART #
- ADD C TO PART NUMBER
FOR CARBIDE
- DIA.

STRIPPER

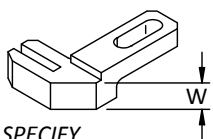

SPECIFY
- MACHINE SIZE
(#246, 1/8, 3/16, 1/4,
11/32, or 3/8)
- W

560 SV ARMS

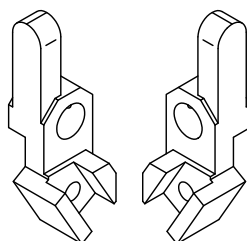

| Style | D | E | F |
|-------|-----|-----|-----|
| A | 4.5 | 4 | 9.5 |
| B | 4 | 5.9 | 8.5 |
| C | 3.5 | 7.4 | 8 |

SPECIFY
- LEFT or RIGHT
- STYLE
- W

246 TRANSFER FINGERS

